

# New Repair Sleeve Coming For Gouges and Suspect Joints In PE Pipe

By **Marco Genoni, GECO System S.p.A.**, Lonate Pozzolo, Italy, and **NUPI Americas**, Houston; **Angelo Fabiano, NYSEARCH-Northeast Gas Association**, New York, NY; and **Brandon Wheeler, NUPI Americas**, Houston

**N**ew repair fittings for live PE pipe are becoming available. The developers expect the solutions to alter the way PE pipe systems are managed and maintained. The new solutions are a repair patch fitting for defective butt fusions and a repair sleeve that is said to be able to accommodate pipe defects and gouges of varying lengths. The solutions have been developed by GECO System S.p.A. of Italy, NUPI Americas and NYSEARCH.

The fittings being rolled out now are for 4-inch PE and are designed to be installed under live conditions at pressures up to 124 psig. The fittings allow repair without removing the damaged or defective section, whether it is a suspect butt fusion joint or a pipe gouge greater than 10% of the wall thickness.

The butt fusion repair fitting, currently being marketed by GECO/NUPI Americas, has met all ASTM requirements. It is known as the Eloffit Repair Patch (ERP). The second fitting, designed to repair PE pipe gouges, is under development. It is called the Variable Length Repair Sleeve (VLR).

Third-party damage and the aging of the system are the two most prominent challenges faced by those responsible for maintaining and safely operating the plastic natural gas pipe network. PE pipe damages greater than 10% wall thickness and defects, in most cases, require the pipe section to be removed. For pipe replacement under live conditions, the pipe section must be isolated by either squeeze-off or by installing a bypass which can be an expensive and time-consuming process. The ERP and VLR fittings for repairing butt fusion joints or severe pipeline gouges will provide the following benefits:

- Smaller excavations,
- Less repair time,
- No loss of service by customers in the event of a shutdown,
- Reduced risk and improved safety, and
- Less expense.

## Current Repair Practice

If a butt fusion joint is determined to be defective, operators of the network have to replace or repair it. Before the introduction of ERP, there was no available technology to repair the joint. Utilities had to follow a time-consuming, costly and disruptive process that involved customer interruption.

The process involves digging a long excavation along the axis of the pipe. This allows access to two points on both sides of the butt fusion joint far enough from the

joint to “squeeze” the pipe off to isolate a suspect joint. Then the pipe is manually squeezed with specialized equipment to shut down the flow through the pipe. In certain circumstances where gas is not being supplied from both ends, a temporary bypass is required, which increases repair costs. A pipe length of about 2-3 feet — which includes the joint — is cut and removed and a new pipe section is installed with two couplings.

While this process is routine, several disadvantages come to light. First, the excavation and restoration needs to be enlarged and therefore results in more expense, especially in urban environments. Secondly, the two squeeze-off sites are points of potential future concern, particularly with some of the older PE resins.

Even though in years past the gas industry had been able to squeeze off plastic pipe safely, in recent years there has been an increase in incidents of pipes leaking at squeeze-off points. For this reason, concern is increasing over the squeezing off of plastic pipe. Finally, the squeeze off may result in loss of service to customers. This inconvenience requires the utility to have to relight the customers’ appliance pilot lights, a process that entails utility personnel gaining access to the building.

## Repair Solution

GECO systems S.p.A. and NYSEARCH are collaborating to develop the two electrofusion fittings. Both are made of PE 100 (PE 4710) materials and have unique designs that provide for a 360° electrofusion to take place around the outer surface of the pipe. To assure complete fusion, the flange-ends or wing sections are also fused to complete the process.

## ERP

The ERP was originally developed for repairing butt fusion joints of questionable integrity under live conditions. The patch can also be used as a repair for pipes that have small-size defects or gouges. The fitting is distributed by NUPI Americas and Mulcare (in the Northeast).

The patch is 8.66 inches long. It consists of two separate, non-identical, shells that are bolted together over the pipe at the point of the butt fusion. Indentations in the center of the inside surfaces of the two sleeves are designed to accommodate the butt fusion bead. Therefore, the fusion bead does not have to be disturbed.



## Product Testing

The ERP fitting meets all ASTM requirements specified in “F1055-98: Electrofusion Type Polyethylene Fittings For Outside Diameter Controlled Polyethylene Pipe And Tubing.” Pressure testing has confirmed that the fitting can be installed successfully on live PE pipe with internal pressures up to 124 psig. Since the fitting is reinforced around the entire circumference, it can be installed over damages/gouges up to five inches in length on the pipe surface.





ERP During Hydrostatic Burst Test.



Using the alignment tool.

NYSEARCH member companies provided additional testing over and above ASTM requirements. As a result, it was determined that ERP fittings with the current electrofusion requirements are not acceptable for thin-wall pipe (4-inch DR17 and DR21). GECO Systems is investigating this issue to establish the proper fusion parameters (voltage, temperature and time) needed for DR17 pipe repairs. Although DR17 pipe materials are seldom found in today's gas distribution systems, there may be more opportunities to use these materials with the forthcoming design factor change.

### ERP Field Installations

Several companies have successfully installed ERP fittings over suspected butt fusion joints that were found not to be acceptable for a variety of reasons which included: substandard bead-width, pipe joint misaligned and/or pipe joint deflection/miter. Being able to install ERP fittings in lieu of pipe section replacements in these situations has saved money.

The ERP and VLRS installation procedure is similar to the installation of electrofusion couplings. However, instead of a single fitting, the repair sleeve is in two halves and has flange/wing extensions. The pipe is prepared with standard scraping tools prior to installing the ERP and VLRS sleeves. The ERP is installed with a special alignment tool and a clamping system to squeeze and hold the fitting flanges together during the fusion process.

Both repair fittings have two barcodes. One is for a specific circumferential electrofuse and the other is for the flange section. The fittings are designed to be installed with any standard electrofusion processor. Additional electrofusion wires are required for the installation and the adapter pins must be 4 mm in size.

### VLRS

The VLRS is expected to be available for introduction into the U.S. market in 2008. The VLRS is a repair sleeve for damaged PE pipe with the ability to accommodate gouges of any length. It consists of fittings that can be arranged consecutively so that — when electrofused — they form one continuous sleeve that re-establishes the integrity of the damaged pipe.

The single sleeve is approximately 16 inches long and can repair a gouge length of up to 10 inches long. Longer damages

or gouges require multiple VLRS fittings. Both the single and multiple applications need a special alignment tool. Additionally, the special VLRS design allows for the fitting-ends to overlap each other, thereby creating one continuous electrofusion between the pipe and each VLRS fitting.

Fitting end caps are used and electrofused at the same time as the fitting. The mold for these sleeves is nearly complete and fittings will be produced and tested by late 2007. Following initial inspection, the sleeves will undergo rigorous testing under the applicable ASTM standards as well as additional testing specified by NYSEARCH member companies.

### Conclusions

The ERP Butt Fusion Repair Patch, introduced by NUPI Americas into the U.S. market under the brand name Elofit, has been developed with funding and technical support from NYSEARCH and its member companies. The patch can be used to rehabilitate butt fusion joints of questionable integrity. In addition, it can be used as a coupling and repair patch for damaged PE pipe as long as

the gouges are small in length.

The Variable Length Repair Sleeve has been developed to repair damaged PE pipe with damage of any length. This product is being developed and tested by GECO Systems.

The principal application for these fittings is the repair of compromised and defective butt fusion joints and PE pipe that would typically need to be replaced. The ERP and VLRS fittings were originally intended for the natural gas distribution industry, but they can also benefit other industries such as the water industry. The operational efficiencies and increased safety obtained through the use of these repair fittings are expected to revolutionize the way plastic systems are maintained. They are expected to inspire the development of a new generation of fittings along the same line. **PE&GJ**

*Authors: Marco Genoni is with GECO System S.p.A., Lonate Pozzolo, Italy and NUPI Americas, Houston, TX. Angelo Fabiano is with NYSEARCH-Northeast Gas Association, New York, NY. Brandon Wheeler is sales manager for NUPI Americas, Houston, TX.*

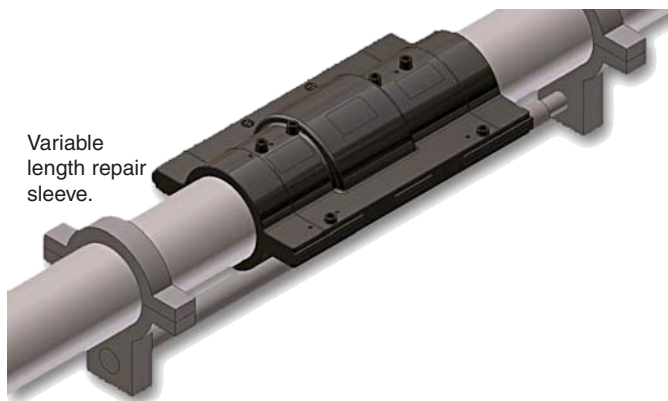

Variable length repair sleeve.